

# V-1101A

## ONE ZONE ONE-WAY PAGE ADAPTER

### INTRODUCTION

The V-1101A, is a One Zone One-Way Page Adapter for use with most electronic or electromechanical telephone systems.

These instructions contain the specifications and information necessary to install, operate, and maintain the One Zone One-Way Page Adapter.

This paging unit has received an FCC type KX registration and is designed to be used with FCC registered key telephone systems.

In accordance with FCC rules with applicable tariffs, this intercom unit may only be installed with the authorization of the owner of the host system.

The FCC Registration Number BAF9I7-69358-KX-N, will be listed in the affidavits filed with the telephone company; it will also be recorded in the system log kept by installation and maintenance personnel. The local telephone company is to be notified of the FCC Registration Number when this intercom unit is installed.

### SPECIFICATIONS

#### Purpose

To provide telephone system access to a single zone of one-way paging.

#### Features

- Electronic key system line key access
- PABX loop trunk port access
- 1A2 line button access
- 1A2 intercom access
- Page port access
- Directly drives Valcom one-way amplified speaker assemblies
- Background music input



#### Capacity

- The V-1101A is a one zone single talkpath unit
- Each V-1101A will drive up to 150 Valcom one-way amplified speaker assemblies

#### Dimensions/Weight

- 7.1"H x 5.9"W x 2.1"D  
(18.03cm H x 14.99cm W x 5.33cm D)
- 2.3 lbs. (1.04 kg)

#### Nominal Specifications

Input:	
Impedance	600 Ohms
Level	-10dBm
Output:	
Impedance	8 Ohms
Level	-10dBm

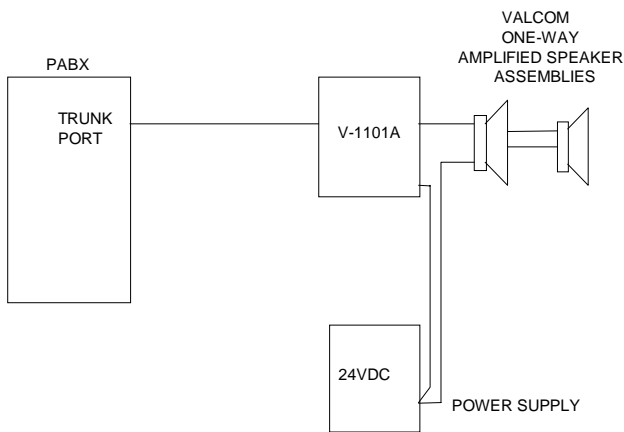

FIGURE 1 - TYPICAL PABX INSTALLATION

## Power Requirements

Voltage: -21.5 to -26 Vdc  
"A" and "B" battery

Current: "A" Battery, 50 mA\*  
"B" Battery, 100 mA

\* ("A" Battery = filtered talk battery)

## Environment

Temperature: 0 to 50 Degrees C  
Humidity: 0 to 85% non-precipitating

## DESIGN

### General

The Valcom V-1101A One-Zone One-Way Page Adapter is designed to provide access to paging from a standard PABX loop trunk port, an electronic key system or 1A2 key system C. O. line button, or a 1A2 key system intercom number. In some cases, access is also possible from a PABX or Electronic Key System page port.

**REMEMBER:** All Valcom paging systems are made up of three basic components: a page control unit, speakers, and a power supply.

When one-way amplified speaker assemblies are specified in this manual, consult your Valcom catalog for the styles available. Once the style and quantity of speakers is determined, select the appropriate power supply after referring to the Valcom One-Way Paging VSP or the Valcom catalog.

In addition to the parts listed in each of the following sections, you will need a 66B type punch down block and a 25-pair cable with a female amphenol connector. These may be purchased from Valcom as a unit with the cable and block already connected and installed on a mounting frame (part # VM-101).

### Electronic Key or PABX Access

When using the V-1101A with an electronic key system or PABX, the following equipment will be required:

- (1) V-1101A One Zone One-Way Page Adapter
- (1) C. O. Line Card (electronic key system) or (1) Loop Trunk Card
- Valcom one-way amplified speaker assemblies (quantity and style determined by specific installation)
- A -24 Vdc power supply (size and quantity determined by number and style of speakers)

Operation: Press the appropriate line key (electronic key system) or dial the appropriate trunk access code (PABX). You will immediately be connected to the paging speakers. Make your announcement. The V-1101A will automatically disconnect when you hang up.

### 1A2 Key Button Access

When accessing the V-1101A from a 1A2 key system line button, the following equipment will be required:

- (1) V-1101A One Zone One-Way Page Adapter
- Valcom one-way amplified speaker assemblies (quantity and style determined by specific installation)
- A -24 Vdc power supply if the existing key system supply is not adequate (the power requirements are determined by number and style of speakers)

**NOTE:** A C.O. line card is NOT required in this application.

Operation: Press the appropriate line button. You will immediately be connected to the paging speakers. Make announcement. The V-1101A will automatically disconnect when you hang up.

### 1A2 Intercom Access

When accessing the V-1101A from a bell/ buzzer intercom connected to a 1A2 key system, the following equipment will be required:

- (1) V-1101A One Zone One-Way Page Adapter
- (1) Unused intercom number
- Valcom one-way amplified speaker assemblies (quantity and style determined by specific installation)
- A 24 Vdc power supply if the existing key system supply is not adequate (power requirements are determined by number and style of speakers)

NOTE: The intercom used MUST supply a holding ground or page control lead to properly operate the V-1101A. A page control lead is a lead that supplies Ground whenever the intercom is in use, and which is Open when the intercom is idle. Contact the manufacturer of your intercom if you have questions about this lead.

Operation: Press the intercom button and dial the number assigned to the V-1101A. You will then be connected to the paging speakers. Make announcement. The V-1101A will automatically disconnect when you hang up.

### **Page Port Access**

CAUTION: To use the V-1101A on a PABX or electronic key system page port, the telephone system MUST SUPPLY both an audio pair AND a dry contact closure.

When accessing the V-1101A from a page port, the following equipment will be required:

- (1) V-1101A One Zone One-Way Page Adapter
- Telephone system page card (if page outputs are not built in)
- Valcom one-way amplified speaker assemblies (quantity and style determined by specific installation)
- A -24 Vdc power supply (size and quantity determined by number and style of speakers)

Operation: Follow the telephone system manufacturer's instructions for accessing paging. Make announcement. The V-1101A will automatically disconnect when you hang up.

### **Background Music**

Background music may be connected to the V-1101A when using any of the above configurations. The background music will automatically cut off when the paging is accessed.

The background music source should have an output impedance of approximately 8 ohms. An output level of 1 watt will be more than sufficient to drive the

amplified speakers. The background music source must have it's own volume control.

The wiring of each arrangement is covered in the next section.

## **INSTALLATION**

### **General**

These instructions cover the installation procedures for the Valcom V-1101A and any associated equipment. Please consult practices for other manufacturer's equipment if any other equipment is being used. Refer to Figure 2 for connection block pinouts.

The following sections contain step-by-step instructions for wiring the Valcom V-1101A one zone one-way page adapter. Each instruction is preceded by a line. Place a check on the appropriate line as the instruction is completed. The instructions also include tests along the way to verify connections have been made correctly. If these steps are followed exactly, installation of your Valcom system will go smoothly and quickly. If the results of a test do not correspond with what is shown, DO NOT PROCEED UNTIL THE PROBLEM HAS BEEN CORRECTED.

— NOTE: To facilitate system testing and balancing, be sure to set the individual volume controls at approximately 1/2 volume when installing one-way amplified speaker assemblies.

### **Mounting**

NOTE: DO NOT install the V-1101A or its wiring closer than 18" to a power supply or any equipment that generates electrical noise.

- 1. If you are using the Valcom VM-101 mounting frame:
  - (a) Using two #6 3/4" wood screws, mount the frame on a vacant space on the backboard with the telephone system common equipment.
  - (b) Using the bolts supplied, attach the V-1101A to the mounting frame.
  - (c) Plug the amphenol ended cable into the V-1101A.
  - (d) Attach the V-1101A terminal designation strip to the punch down block on the frame.
- 2. If you are using a separate punch down block and cable:

- \_\_\_ (a) Using two #6 3/4" wood screws, mount the unit in a vacant space on the backboard with the telephone system common equipment.
- \_\_\_ (b) Mount a 66 type punch down block near the unit.
- \_\_\_ (c) On one column of the block, completely punch down a 25 pair cable. The other end of the cable should have a female amphenol connector.
- \_\_\_ (d) Plug the amphenol connector into the V-1101A.
- \_\_\_ (e) Mark the punch down block as shown in Figure 2.

### **Power Connections**

- \_\_\_ 1. Unplug power supply.
- \_\_\_ 2. Connect -24 Vdc "B" battery (may be referred to as "-" or "signal battery") from power supply to BB (S/V) of the V-1101A.
- \_\_\_ 3. Connect -24 Vdc Ground ("B" ground, "+", or "signal" ground) from the power supply to BG (V/S).
- \_\_\_ 4. Connect -24 Vdc "A" battery (may be referred to as "-" or "talk battery") from the power supply to AB (BR/V) of the V-1101A.
- \_\_\_ 5. Connect -24 Vdc Ground ("A" ground, "+", or "talk ground") from the power supply to AG (V/BR).
- \_\_\_ 6. Connect GROUND from the power supply to a good Earth or Water Pipe ground.

- 7. Power Test:
  - \_\_\_ (a) Plug in power supply.
  - \_\_\_ (b) Using a screwdriver, momentarily short between the BFT (W/S) and BFR (S/W) leads of the V-1101A and listen for a relay to operate in the unit.
  - \_\_\_ (c) If no relay is heard:
    - \_\_\_ (1) Unplug power supply.
    - \_\_\_ (2) Verify the V/BR and V/S pairs are properly connected at the punch-down block and in the amphenol.
    - \_\_\_ (3) Return to step 2, and verify all connections.
  - \_\_\_ (d) If a relay is heard, proceed to step 8.
- \_\_\_ 8. Unplug power supply.

### **Connecting Arrangements**

NOTE: Place a check by the arrangement being used and proceed to the Figure indicated for step-by-step installation instructions.

- \_\_\_ 1. Electronic key system line key access: Proceed to Figure 3.
- \_\_\_ 2. PABX loop trunk port access: Proceed to Figure 3.
- \_\_\_ 3. 1A2 key system line button access: Proceed to Figure 4.
- \_\_\_ 4. 1A2 key system intercom access: Proceed to Figure 5.
- \_\_\_ 5. Electronic key or PABX page port access: Proceed to Figure 6.

## FIGURE 2

			A	B	C	D	E	F
TIP _____	T	_____	_____	26	_____	W/BL	_____	_____
RING _____	R	_____	_____	1	_____	BL/W	_____	_____
HOLDING GROUND _____	H	_____	_____	27	_____	W/O	_____	_____
ICM START _____	SIG	_____	_____	2	_____	O/W	_____	_____
GROUND START _____	DIR	_____	_____	28	_____	W/GR	_____	_____
		_____	_____	3	_____	GR/W	_____	_____
NORMALLY OPEN CONTACT <input type="checkbox"/>	CT2	_____	_____	29	_____	W/BR	_____	_____
BATTERY FEED TIP _____	CT2	_____	_____	4	_____	BR/W	_____	_____
BATTERY FEED RING _____	BFT	_____	_____	30	_____	W/S	_____	_____
	BFR	_____	_____	5	_____	S/W	_____	_____
NORMALLY OPEN CONTACT <input type="checkbox"/>	A1	_____	_____	31	_____	R/BL	_____	_____
	A1	_____	_____	6	_____	BL/R	_____	_____
NORMALLY OPEN CONTACT <input type="checkbox"/>	A2	_____	_____	32	_____	R/O	_____	_____
	A2	_____	_____	7	_____	O/R	_____	_____
MUSIC INPUT _____	MT	_____	_____	33	_____	R/G	_____	_____
	MR	_____	_____	8	_____	G/R	_____	_____
PAGE OUT _____	PG	_____	_____	34	_____	R/BR	_____	_____
	OUT	_____	_____	9	_____	BR/R	_____	_____
		_____	_____	35	_____	R/S	_____	_____
		_____	_____	10	_____	S/R	_____	_____
		_____	_____	36	_____	BK/BL	_____	_____
		_____	_____	11	_____	BL/BK	_____	_____
		_____	_____	37	_____	BK/O	_____	_____
		_____	_____	12	_____	O/BK	_____	_____
		_____	_____	38	_____	BK/G	_____	_____
		_____	_____	13	_____	G/BK	_____	_____
		_____	_____	39	_____	BK/BR	_____	_____
		_____	_____	14	_____	BR/BK	_____	_____
		_____	_____	40	_____	BK/S	_____	_____
		_____	_____	15	_____	S/BK	_____	_____
		_____	_____	41	_____	Y/BL	_____	_____
		_____	_____	16	_____	BL/Y	_____	_____
		_____	_____	42	_____	Y/O	_____	_____
		_____	_____	17	_____	O/Y	_____	_____
		_____	_____	43	_____	Y/G	_____	_____
		_____	_____	18	_____	G/Y	_____	_____
		_____	_____	44	_____	Y/BR	_____	_____
		_____	_____	19	_____	BR/Y	_____	_____
-24V START _____	-24V DIR	_____	_____	45	_____	Y/S	_____	_____
		_____	_____	20	_____	S/Y	_____	_____
		_____	_____	46	_____	V/BL	_____	_____
		_____	_____	21	_____	BL/V	_____	_____
		_____	_____	47	_____	V/O	_____	_____
		_____	_____	22	_____	O/V	_____	_____
		_____	_____	48	_____	V/G	_____	_____
		_____	_____	23	_____	G/V	_____	_____
FILTERED -24VDC _____	AG	_____	_____	49	_____	V/BR	_____	_____
	AB	_____	_____	24	_____	BR/V	_____	_____
UNFILTERED -24VDC _____	BG	_____	_____	50	_____	V/S	_____	_____
	BB	_____	_____	25	_____	S/V	_____	_____

NOTE: AG AND BG ARE "+", AB AND BB ARE "-"

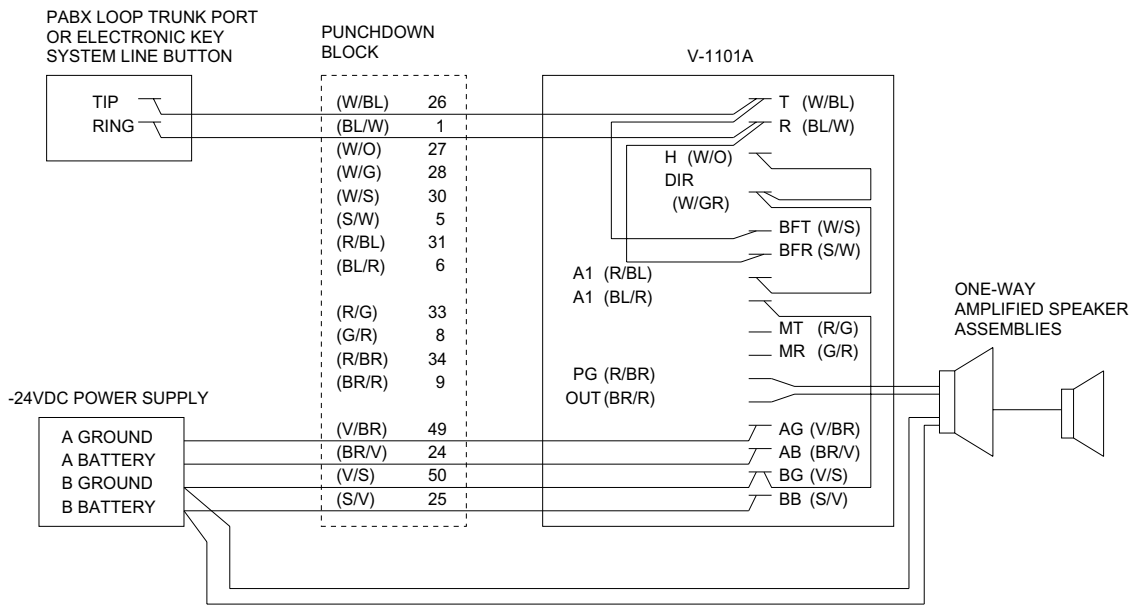

FIGURE 3  
ELECTRONIC KEY SYSTEM LINE BUTTON ACCESS OR PABX LOOP TRUNK ACCESS

### WIRING INSTRUCTIONS

Place a check by each step as it is completed.

- \_\_\_ 1. Add a strap on the V-1101A punchdown block from Tip to BFT (W/BL to W/S).
- \_\_\_ 2. Add a strap from Ring to BFR (BL/W to S/W).
- \_\_\_ 3. Add a strap from H to DIR (W/O to W/GR).
- \_\_\_ 4. Add a strap from DIR to Red/Blue (W/GR to R/BL).
- \_\_\_ 5. Add a strap from Blue/Red to BG (BL/R to V/S).
- \_\_\_ 6. Connect Tip of the one-way amplified speaker assemblies to the V-1101A PG lead (R/BR).
- \_\_\_ 7. Connect Ring of the speakers to the OUT lead (BR/R).
- \_\_\_ 8. Connect the GND terminal of the speakers (black lead of horns) to the power supply Ground ("+" or "B Ground").
- \_\_\_ 9. Connect the -24 Vdc lead of the speakers (white lead of horns) to the power supply 24 Vdc ("- or "B Battery").
- \_\_\_ 10. Plug in the power supply.
- \_\_\_ 11. Test the unit by connecting a lineman's test set across the V-1101A Tip and Ring:
  - \_\_\_ (a) Go "off hook" and speak. Your voice should come out the speakers.
  - \_\_\_ (b) If you hear the page: disconnect your test set and go to step 12.
  - \_\_\_ (c) If you do not hear the page:
    - (1) unplug the power supply;
    - (2) go back to step 1 and recheck all your connections.
- \_\_\_ 12. Connect the tip (W/BL) of the V-1101A to Tip of your telephone system loop trunk port (PABX) or C.O. line position (E-key).
- \_\_\_ 13. Connect the Ring (BL/W) of the V-1101A to Ring of the telephone system.
- \_\_\_ 14. Test the system by dialing the proper trunk access code (PABX) or pressing the appropriate line key (E-key) and speaking into the handset:
  - \_\_\_ (a) If you hear the page go to 15.
  - \_\_\_ (b) If you do not hear the page verify proper telephone system configuration and programming. If you have programming questions contact the telephone system manufacturer.
- \_\_\_ 15. Adjust the volume controls on the individual speakers to the desired levels.
- \_\_\_ 16. If background music is to be provided:
  - \_\_\_ (a) Connect the music source to the V-1101A MT and MR (R/G and G/R).
  - \_\_\_ (b) With the V-1101A idle adjust the music source volume control to provide the desired level at the speakers.

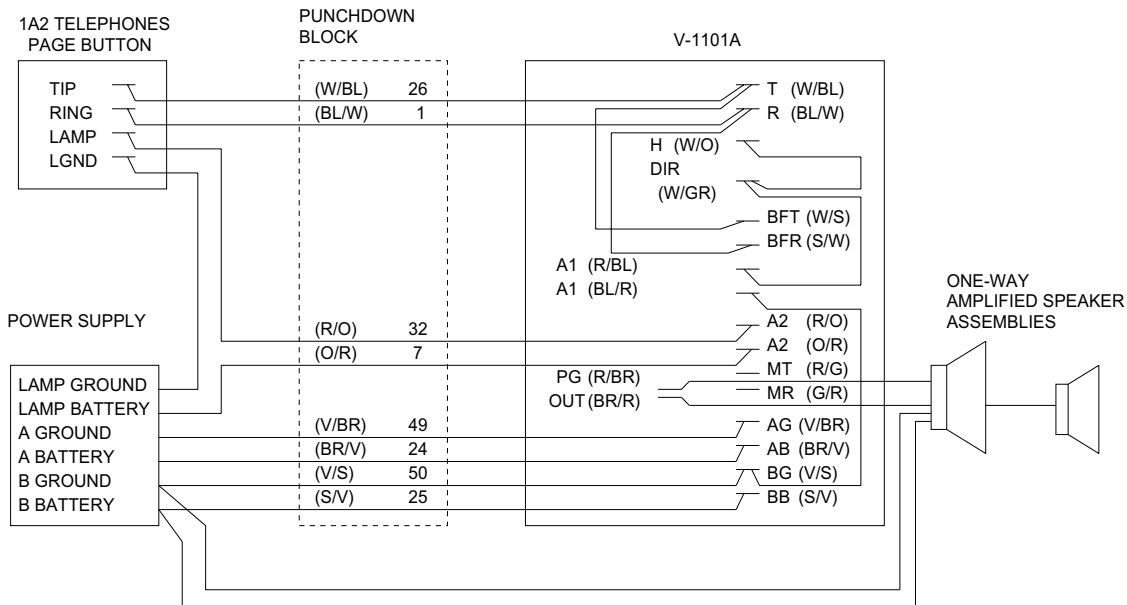

FIGURE 4  
1A2 KEY SYSTEM LINE BUTTON ACCESS

## WIRING INSTRUCTIONS

Place a check by each step as it is completed.

- \_\_\_ 1. Add a strap on the V-1101A punchdown block from Tip to BFT (W/BL to W/S).
- \_\_\_ 2. Add a strap from Ring to BFR (BL/W to S/W).
- \_\_\_ 3. Add a strap from H to DIR (W/O to W/GR).
- \_\_\_ 4. Add a strap from DIR to Red/Blue (W/GR to R/BL).
- \_\_\_ 5. Add a strap from Blue/Red to BG (BL/R to V/S).
- \_\_\_ 6. Connect Tip of the one-way amplified speaker assemblies to the V-1101A PG (R/BR) lead.
- \_\_\_ 7. Connect Ring of the speakers to OUT (BR/R).
- \_\_\_ 8. Connect the GND terminal of the speakers (black lead of horns) to the power supply Ground ("+" or "B Ground").
- \_\_\_ 9. Connect the -24 Vdc lead of the speakers (white lead of horns) to the power supply -24 Vdc ("- or "B Battery").
- \_\_\_ 10. Plug in the power supply.
- \_\_\_ 11. Test the unit by connecting a lineman's test set across the V-1101A Tip and Ring:
  - \_\_\_ (a) Go "off hook" and speak. Your voice should come out the speakers.
  - \_\_\_ (b) If you hear the page: disconnect your test set and go to step 12.
  - \_\_\_ (c) If you do not hear the page:
    - (1) unplug the power supply;
    - (2) go back to step 1 and recheck all your connections.
- \_\_\_ 12. Cross-connect the tip (W/BL) of the V-1101A to Tip of the paging line button of all your telephones.
- \_\_\_ 13. Cross-connect Ring (BL/W) of the V-1101A to Ring of all the telephone paging buttons.
- \_\_\_ 14. Cross-connect the Red/Orange (R/O) of the V-1101A to the lamp lead of the paging line button on all telephones.
- \_\_\_ 15. Connect from the V-1101A Orange/Red (O/R) to the power supply 10 Vac.
- \_\_\_ 16. Test the system by pressing the page line button and speaking into the handset:
  - \_\_\_ (a) If you hear the page and see a lamp on the phones go to Step 17.
  - \_\_\_ (b) If you do not get a lamp verify steps 14 and 15 have been performed correctly.
  - \_\_\_ (c) If you do not hear the page verify steps 12 and 13 have been performed correctly and all connections are good.
- \_\_\_ 17. Adjust the volume controls on the individual speakers to the desired levels.
- \_\_\_ 18. If background music is to be provided:
  - \_\_\_ (a) Connect the music source to the V-1101A MT and MR (R/G and G/R).
  - \_\_\_ (b) With the V-1101A idle adjust the music source volume control to provide the desired level at the speakers.

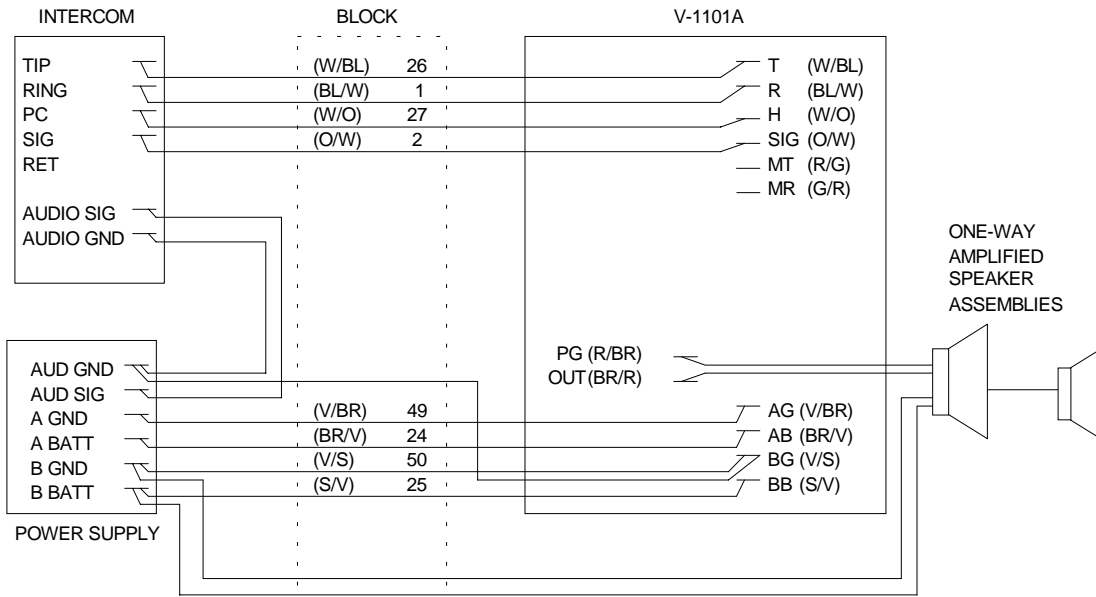

FIGURE 5  
1A2 INTERCOM ACCESS

### WIRING INSTRUCTIONS:

Place a check by each step as it is completed.

- \_\_\_ 1. Connect from the V-1101A Tip (W/BL) to Tip of your intercom.
- \_\_\_ 2. Connect from the V-1101A Ring (BL/W) to the intercom Ring.
- \_\_\_ 3. Connect from the V-1101A H (W/O) to the intercom page control lead (may be called Holding Ground).
- \_\_\_ 4. Connect from the V-1101A SIG (O/W) to the intercom number being used for page access. **Important Note:** The V-1101A requires only one lead from the intercom number. On Valcom intercoms this is the "S" lead. On other intercoms it is usually the "R" or "Ring" lead.
- \_\_\_ 5. Connect from the V-1101A BG (V/S) to one of the following:
  - \_\_\_ (a) Power supply ring ground if using 105 Vac for intercom signaling.
  - \_\_\_ (b) Power supply 18 Vac ground if using 18 Vac for intercom signaling.
  - \_\_\_ (c) Power supply 10 Vac ground if using 10 Vac for intercom signaling.
- \_\_\_ 6. Connect Tip of the one-way amplified speaker assemblies to the V-1101A PG (R/BR) (R/BR) lead.
- \_\_\_ 7. Connect Ring of the speakers to OUT (BR/R).
- \_\_\_ 8. Connect the GND terminal of the speakers (black lead of horns) to the power supply Ground ("+" or "B Ground").
- \_\_\_ 9. Connect the -24 Vdc lead of the speakers (white lead of horns) to the power supply -24 Vdc terminal ("- or "B Battery").
- \_\_\_ 10. Plug in the power supply.
- \_\_\_ 11. Test the system by pressing down the intercom button, dialing the code for page access, and speaking into the handset.
  - \_\_\_ (a) If you hear the page go to step 12.
  - \_\_\_ (b) If you do not hear the page unplug the power supply, go back to step 1, and verify all your connections. Also repeat the power test in power connection section, step 7.
- \_\_\_ 12. While paging, adjust the volume controls on the individual speakers to the desired levels.
- \_\_\_ 13. If background music is to be provided:
  - \_\_\_ (a) Connect the music source to the V-1101A MT and MR (R/G and G/R).
  - \_\_\_ (b) With the V-1101A idle, adjust the music source volume control to provide the desired level at the speakers.



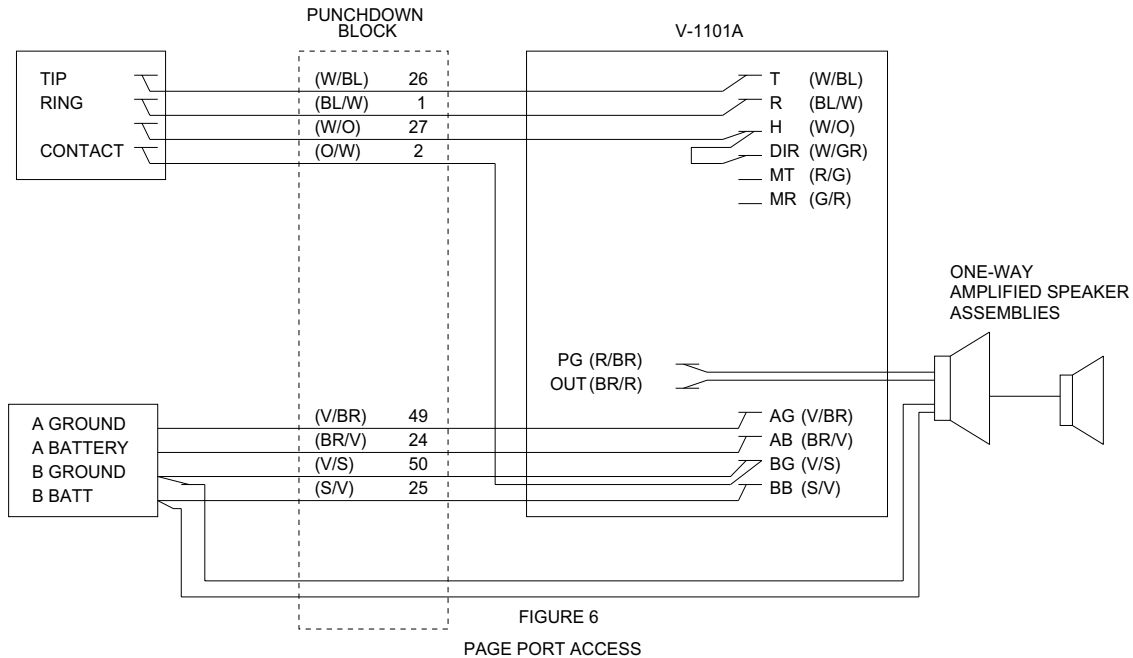

### WIRING INSTRUCTIONS:

Place a check by each step as it is completed.

- \_\_\_ 1. Connect the Tip (W/BL) of the V-1101A to Tip of your telephone system page port.
- \_\_\_ 2. Connect the Ring (BL/W) lead to Ring of the page port.
- \_\_\_ 3. Add a strap on the V-1101A punchdown block from H to DIR (W/O to W/GR).
- \_\_\_ 4. Connect the V-1101A BG (V/S) lead to one side of the page port dry contact closure.
- \_\_\_ 5. Connect the other side of the contacts to the V-1101A H (W/O) lead.
- \_\_\_ 6. Connect Tip of the one-way amplified speaker assemblies to PG (R/BR) of the V-1101A.
- \_\_\_ 7. Connect Ring of the speakers to OUT (BR/R).
- \_\_\_ 8. Connect the GND terminals of the speakers (black lead of horns) to the power supply Ground ("+" or "B Ground").
- \_\_\_ 9. Connect the -24 Vdc lead of the speakers (white lead of horns) to the power supply -24 Vdc terminal ("- " or "B Battery").
- \_\_\_ 10. Plug in the power supply.
- \_\_\_ 11. Test the system by dialing the telephone system page access code or pressing the page button and speaking into the handset:
  - \_\_\_ (a) If you hear the page go to step 12.
  - \_\_\_ (b) If you do not hear the page verify steps 1-10 have been performed properly and all connections are good. Also verify proper telephone system configuration and programming. If you have programming questions contact the telephone system manufacturer.
- \_\_\_ 12. Adjust the volume controls on the individual speakers to the desired levels while paging.
- \_\_\_ 13. If background music is to be provided:
  - \_\_\_ (a) Connect the music source to the V-1101A MT and MR (R/G and G/R).
  - \_\_\_ (b) With the V-1101A idle adjust the music source volume control to provide the desired level at the speakers.

## **OPERATION**

### **General**

The V-1101A contains the required circuitry to allow paging access from most types of telephone systems.

To operate correctly, the V-1101A must receive two signals: a ground on the Holding Ground input and either a momentary AC signal on the Signal Input lead or a momentary or continuous ground on the Ground Start lead.

The unit may be wired for loop start operation for use on PABX's or electronic key systems (Figure 3). In this application the unit will supply the -24 Vdc talk battery required by the telephone system trunk card. The holding ground and start leads required by the page unit will be supplied internally in this case.

Connections for access by a 1A2 line button are similar to those above, except that the unit is cross-connected directly to the button of the telephone instead of to a trunk card (Figure 4). A spare set of relay contacts is used to switch lamp voltage to the phones.

When connecting the V-1101A to an intercom number (Figure 5) four leads are required from the intercom: Tip and Ring to supply audio, a Page Control Lead, and a Signal Lead. The Page Control Lead must supply a Ground whenever the intercom is in use, and must be open when the intercom is idle. This lead is used to release the V-1101A at the end of a page. The intercom may be wired to use 10 Vac, 18 Vac, or 105 Vac for signaling. The intercom signal must be momentary, i.e., the signal must be present for approximately 1 second and then drop off. A continuous signal will prevent the V-1101A from operating.

When connecting the V-1101A to a page port (Figure 6) a Ground must be connected through the dry contact closure of the telephone system page card to both the Holding Ground and the Ground Start terminals of the V-1101A.

Once the V-1101A has been activated it will remove the background music (if connected) from the speakers and allow you to page. The unit will stay active until you hang up, at which time the holding ground will be removed and the unit will be allowed to release.

## **TECHNICAL ASSISTANCE**

When trouble is reported, verify the unit is properly connected and there are no broken connections leading to this unit.

Assistance in troubleshooting is available from the factory. When calling, you should have a VOM and a test set and be calling from the job site. Call (540) 427-3900 and ask for Technical Support, or call (540) 427-6000 for Valcom 24-hour Automated Support or visit our website at <http://www.valcom.com>.

Valcom equipment is not field repairable. Valcom, Inc. maintains service facilities in Roanoke, VA. Should repairs be necessary, attach a tag to the unit clearly stating company name, address, phone number, contact person, and the nature of the problem.

Send the unit to:  
**Valcom, Inc.**  
**Repair & Return Dept.**  
**5614 Hollins Road**  
**Roanoke, VA 24019-5056**

## TROUBLESHOOTING CHART

<i>Symptom</i>	<i>Solution</i>
1. No output at speakers.	1. Check for audio on the Red/Brown pair of the V-1101A while paging. <ul style="list-style-type: none"> <li>(a) <b>If audio is present:</b> Verify proper audio and power wiring to speakers. Try connecting a speaker in the equipment room: Connect the Tip and Ring leads directly to the Red/Brown pair of the V-1101A and connect the -24 Vdc and ground leads to the power supply. Test again.</li> <li>(b) <b>If no audio:</b> Refer to Wiring Instructions and complete the power test (step 7). Correct any problems and test again. If there is still no audio, then return to the installation Figure used and verify ALL connections. Use a meter to verify the connections from the punchdown block to the amphenol. If there is still no audio and you used Figure 5 Intercom Access, connect a bell or buzzer to the V-1101A H and SIG leads. Dial the page access number. If the bell or buzzer does not ring, then you are either not getting a page control from the intercom, or you have connected the wrong half of the signal pair to the V-1101A SIG lead.</li> </ul>
2. Music will not cut off during a page.	q

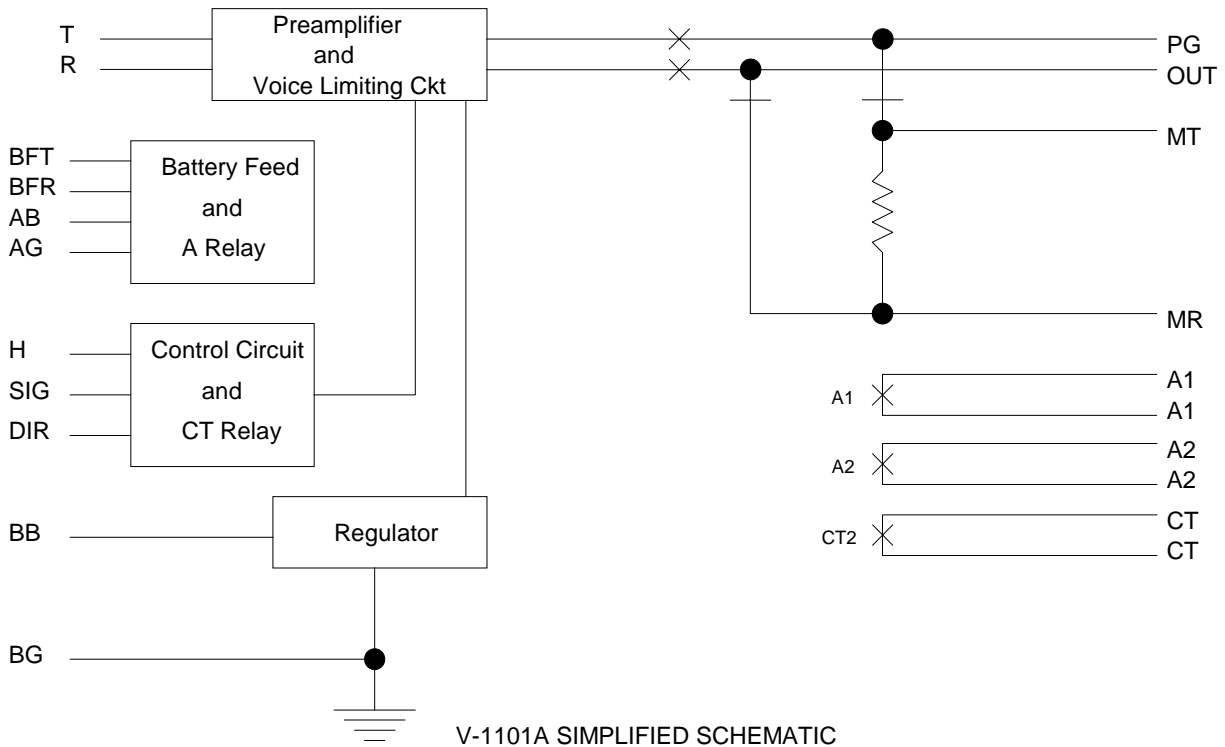

### VALCOM LIMITED WARRANTY

Valcom, Inc. warrants its products to be free from defects in materials and workmanship under conditions of normal use and service for a period of one year from the date of shipment. The obligation under this warranty shall be limited to the replacement, repair or refund of any such defective device within the warranty period, provided that:

1. inspection by Valcom, Inc. indicates the validity of the claim,
2. the defect is not the result of damage, misuse, or negligence after the original shipment.
3. the product has not been altered in any way or repaired by others and that factory sealed units are unopened (A service charge plus parts and labor will be applied to units defaced or physically damaged),
4. freight charges for the return of products to Valcom are prepaid,
5. all units 'out of warranty' are subject to a service charge. The service charge will cover minor repairs (Major repairs will be subject to additional charges for parts and labor).

**This warranty is in lieu of and excludes all other warranties, expressed or implied, and in no event shall Valcom, Inc. be liable for any anticipated profits, consequential damages, loss of time or other losses incurred by the buyer in connection with the purchase, operation, or use of the product.**

This warranty specifically excludes damage incurred in shipment. In the event a product is received in damaged condition, the carrier should be notified immediately. Claims for such damage should be filed with the carrier involved in accordance with the F.O.B. point.

Headquarters:  
Valcom, Inc.  
1111 Industry Avenue  
Roanoke, VA 24013  
Phone: (540) 427-3900  
FAX: (540) 427-3517

In Canada  
CMX Corporation  
35 Van Kirk Drive #11 and 12  
Brampton, Ontario L7A1A5  
Phone: (905) 456-1072  
FAX: (905) 456-2269